



GEANT4-Based Model of the CREAM Timing Charge Scintillation Detector

S. A. I. MOGNET⁴, H. S. AHN¹, P. S. ALLISON⁵, M. G. BAGLIESI⁷, J. J. BEATTY⁵, G. BIGONGIARI⁷, P. J. BOYLE³, T. J. BRANDT⁵, J. T. CHILDERS⁶, N. B. CONKLIN⁴, S. COUTU⁴, M. A. DUVERNOIS⁶, O. GANEL¹, J. H. HAN⁸, H. J. HYUN⁸, J. A. JEON⁸, K. C. KIM¹, J. K. LEE⁸, M. H. LEE¹, L. LUTZ¹, P. MAESTRO⁷, A. MALININ¹, P. S. MARROCCHESI⁷, S. A. MINNICK⁹, S. NAM⁸, S. L. NUTTER¹⁰, I. H. PARK⁸, N. H. PARK⁸, E. S. SEO^{1,2}, R. SINA¹, S. P. SWORDY³, S. P. WAKELY³, J. WU¹, J. YANG⁸, Y. S. YOON^{1,2}, R. ZEI⁷, S. Y. ZINN¹

¹*Institute for Physical Science and Tech., University of Maryland, College Park, MD 20742, USA*

⁴*Pennsylvania State University, University Park, PA 16802, United States of America*

²*Department of Physics, University of Maryland, College Park, MD 20742, USA*

⁵*Department of Physics, Ohio State University, Columbus, OH 43210, USA*

³*Enrico Fermi Institute and Dept. of Physics, University of Chicago, Chicago, IL 60637, USA*

⁶*School of Physics and Astronomy, University of Minnesota, Minneapolis, MN 55455, USA*

⁷*Department of Physics, University of Siena & INFN, Via Roma 56, 53100 Siena, Italy*

⁸*Department of Physics, Ewha Womans University, Seoul 120-750, Republic of Korea*

⁹*Department of Physics, Kent State University, Tuscarawas, New Philadelphia, OH 44663, USA*

¹⁰*Department of Physics, Northern Kentucky University, Highland Height, KY 41099, USA*

¹¹*Department of Physics, Kyungpook National University, Daegu 702-701, Republic of Korea*

sam378@psu.edu

Abstract: The Cosmic Ray Energetics And Mass (CREAM) instrument is a balloon-borne detector designed to measure the cosmic-ray spectrum in the 1-1000TeV energy range, with good charge resolution from protons to iron ($Z = 1$ to 26). The CREAM instrument has had two successful flights, both from McMurdo Station, Antarctica in the 2004-2005 and 2005-2006 Antarctic summer campaigns, with a combined flight duration of approximately 70 days. The CREAM-I instrument consisted of a fast scintillation-based Timing Charge Detector (TCD), a Transition Radiation Detector and a sampling calorimeter. Here we describe a GEANT4-based model for a CREAM TCD scintillation counter, used in characterizing the charge and timing response of the counters to various incident particles. The model incorporates all counter components, including the scintillator, light guides and an approximation of the photomultiplier tube (PMT) readout. We compare the simulated output results to actual event signals.

Introduction

The CREAM TCD consists of 8 identical scintillation charge detector paddles arranged in two crossed layers at the top of the instrument. Each paddle is constructed of Saint-Gobain BC408 plastic scintillator, with twisted-strip adiabatic light guides at each end. The light guides are made from acrylic (BC802) with enhanced UV attenuation [2].

Readout of each paddle is done with two Photonic XP2020 fast PMTs. Each PMT is read out at the anode and 5 dynode taps [2]. Four dynode taps go to custom analog-to-digital peak detectors (ADCs), while the anode and one additional dynode tap each go to two time-to-digital converters (TDCs). By utilizing very fast electronics, the TCD is able to quickly acquire the signal from the primary incident particle, and then reject the contamination from any albedo particles from high-energy showers generated in the calorimeter located 1.1 m below the TCD [3].

Model Overview

A model of a CREAM TCD paddle was constructed using the GEANT4 [1] simulation package. The purpose of this model was to better understand the optical response of the paddles to both the primary cosmic rays, and to albedo particles from the calorimeter.

The complete simulation consists of a GEANT4-based model of one TCD paddle, plus optionally the tungsten calorimeter and associated carbon targets. Optical photon physics is included in a separate module which is then registered with whatever physics model is being used. Output for each event is written to an ASCII file. The output file is read in by a stand-alone C++ program which models PMT and electronics response, and outputs a ROOT [4] tree for analysis.

Detector Definition

The TCD paddle model consists of a block of plastic scintillator of dimensions $120\text{cm} \times 30\text{cm} \times 0.5\text{cm}$, twisted adiabatic light guides, aluminum foil wrapping, a glass face for the PMTs, and small aluminum disks to approximate the PMT photocathodes. Figure 1 illustrates the paddle elements modeled.

The light guide models each consist of 28 individual pieces of BC802 acrylic. The light guide parts are assembled into a `G4LogicalVolume` using repeated iterations of `G4AdditionSolid`. The foil wrapping is constructed in a similar way.

Once all the individual parts for the paddle are assembled into logical volumes, physical instances of all the parts are placed into a `G4AssemblyVolume`. Then one copy of the paddle is placed where desired in the world volume. Using the `G4AssemblyVolume`, we could extend this model to include more than one paddle if desired, though this has not been done.

The calorimeter consists of 20 tungsten plates, plus two carbon targets. By default the calorimeter is not placed in the detector, but it can be inserted with a simple command.

The bulk material properties of BC408, BC802, glass, aluminum, tungsten, and graphite were de-

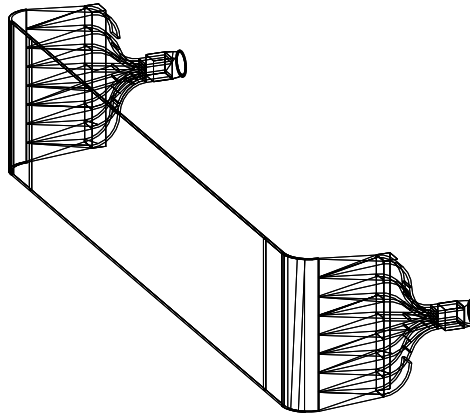

Figure 1: GEANT4 model of a CREAM TCD scintillation paddle. Note that some parts are missing from this picture due to a known rendering issue with GEANT4, however all components are actually present in the code for physics interactions.

finied manually. The optical properties (both bulk and surface) were also defined for all materials present in the paddle using instances of the `G4MaterialPropertiesTable` class. The optical surface properties of each part were also set by creating a `G4OpticalSurface` class for each, and attaching a `G4MaterialPropertiesTable` to it.

One important optical property of the BC408 scintillator is the scintillation yield. This was made adjustable for debugging and prototyping reasons via a `G4UImessenger` class. The yield for BC408 is approximately 10,000 photons/MeV deposited energy [5][7], however the simulation runs were typically done at a value of 3000. The reasons for this were twofold: to approximate the quantum efficiency of the PMTs, and to dramatically increase the speed of the code because there were $2/3$ fewer optical tracks to calculate.

Sensitive Detectors and Hits Collections

Two different types of sensitive detectors were implemented in the model. One detector was used to find the energy deposited in the TCD scintillator paddle, the other to find photon arrival times at each PMT.

In the first implementation of the detector, the scintillator logical volume itself was set as a sensitive detector. The scintillator sensitive detector then yielded the total energy deposited in the scintillator, and the average position of the hit. The sensitive detector then recorded those values into an instance of the `G4VHit` hits collection class.

The PMT sensitive detector is a bit more involved because GEANT4 does not implement a PMT type detector. To work around this limitation, the `G4UserSteppingAction` class is implemented. The boundary status of each track is examined such that those optical photons which reach one of the photocathodes defined in the detector definition each count as a hit. The PMT sensitive detector is called by the stepping action when this occurs, and then the desired quantities are stored in the PMT hits collection.

For each photon which arrives at a PMT we store the following: the PMT struck (pmt ID), the arrival time, the time it entered one of the light guides (to study dispersion), the number of reflections it underwent, and the total distance it traveled from generation.

The detection efficiency of the PMT photocathodes is defined in the detector definition. For a realistic PMT this would be the quantum efficiency of the PMT, and would also be dependent on the wavelength of the incident photons. Since our PMT wavelength response and the output of our scintillator were well matched we did not include any energy dependence in our PMT response. Furthermore, the efficiency of photon detection for our PMTs was set to 100%, because this was compensated for by setting the scintillation yield to 30% as discussed above.

Physics Models and Signal Digitization

This simulation can utilize any of the built-in GEANT4 physics models to handle electromagnetic and hadronic interactions, such as QGSP, QGSC, LHEP. Optical physics is added separately by creating an instance of the `G4VPhysicsConstructor` class to which we add all the relevant physics for the `G4OpticalPhoton` class. We then register this module with any particular physics model that is being used. The

GEANT4 optical processes included were the following: scintillation, Cherenkov, optical absorption, optical Rayleigh scattering and optical boundary processes.

Output for each event was generated in the `G4UserEventAction` class. At the end of each event, the contents of the two hits collections, plus some additional information about the event, are formatted and appended to an ASCII file for later processing. Information stored includes arrival time of photons at each PMT and light guide, energy deposit in the scintillator, position of the primary hit, incidence angle of the primary track, number of reflections for each photon, number of photons absorbed (and in what volume), and charge of the primary.

The PMT output from the GEANT4 simulation is a list of photon arrival times. To produce realistic PMT-like pulses, each photon needs to be convolved with the PMT single photoelectron (PE) response. The average single PE response was measured with an actual flight XP2020 PMT, read out with a fast digital oscilloscope. An average single PE pulse shape was determined using the averaging feature of the oscilloscope.

The convolution of the simulated photon arrival times with the measured single PE response yields a realistic PMT response. This is illustrated in Fig. 2, which shows the average of 256 experimentally measured atmospheric muon pulses, with the average of 1000 simulated muon pulses. An overall 10% scale factor (multiplying by 90%) was applied to the time of the simulated PMT pulse to decrease the width of the pulse. This was introduced to adjust for any systematic bias introduced from slew rate and sampling limitations of the single PE pulse measurement.

Results and Conclusions

Figure 3 shows the average simulated ADC (peak detector plus pedestal) response for 10 GeV protons as a function of the position of the hit along the paddle. This compares with an experimentally measured average attenuation curve also shown in Fig. 3, derived from the CREAM flight data.

A great feature of this sort of model is that it provides us with a tool to better understand the sources

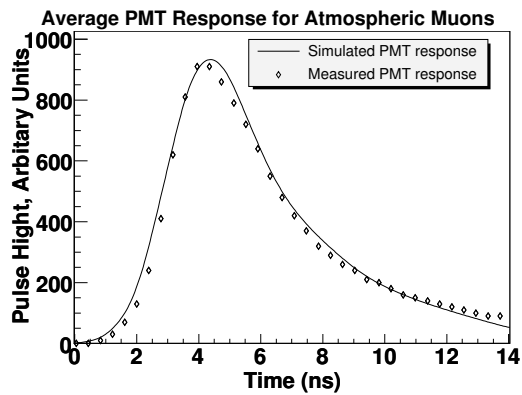

Figure 2: The average PMT response for muons - simulated and measured.

of any non-linearities in the detector response. For example, it can decouple non-linearities from the geometric arrangement and optical properties of the detector from electronics-based effects.

We are also using this package for prototyping analysis strategies of actual data, since the simulation provides an idealized yet still reasonably realistic set of simulated events [6]. One has access to a large number of possible choices of simulated test beams, as well as extra information not measured in a real detector.

Finally this model of one TCD paddle is being used to calibrate the response of the TCD model in a full CREAM instrument Monte Carlo package. The full instrument MC will not have optical physics present, but with sufficient mapping of the single paddle response using the standalone optical model outlined in this paper, the output should be comparable in accuracy.

Acknowledgements

This work is supported by NASA, NSF, INFN, KICOS, MOST and CSBF.

References

- [1] S. Agostinelli et al. GEANT4-A Simulation Toolkit. *Nucl. Inst. & Meth. A*, 506:250–303, 2003.

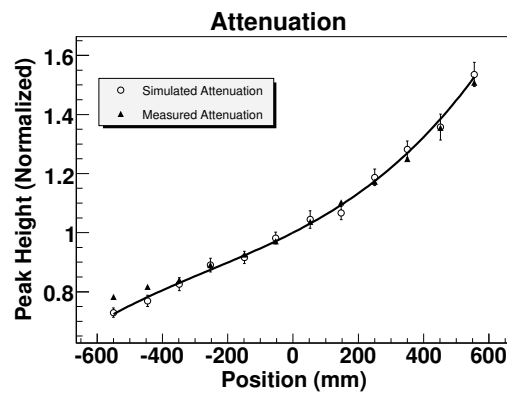

Figure 3: ADC (peak detector) attenuation from simulated 10 GeV protons incident at different positions (in mm) along the length of the paddle, with all values normalized to the center of the paddle.

- [2] H. S. Ahn et al. The Cosmic Ray Energetics And Mass (CREAM) Instrument. *in press in Nucl. Inst. & Meth. A*, 2007.
- [3] J. J. Beatty, et al., and the CREAM collaboration. The Cosmic Ray Energetics and Mass (CREAM) Experiment Timing Charge Detector, Proc. SPIE. *Particle Astrophysics Instrumentation*, 4858:248–+, 2007.
- [4] R. Brun and F Rademakers. Root - an object oriented data analysis framework. *Nucl. Inst. & Meth. A*, 389:81–86, 1997.
- [5] Saint-Gobain Industrial Ceramics. *BC-400/BC-404/BC-408/BC-412/BC-416 Premium Plastic Scintillators (Data Sheet)*.
- [6] J. T. Childers. Timing charge and position analysis from the first CREAM flight. In *30th Int. Cosmic Ray Conf.*, 2007, this conference.
- [7] W. R. Leo. *Techniques for Nuclear and Particle Physics Experiments*. Springer-Verlag, 1994, Revised 2nd edition.